

# D5

# DMX512

## 5 Channel Constant Voltage DMX512 & RDM Decoder / Master

- 5 channels constant voltage output, Max. 6A current per channel, up to 720W output power.
- Master & decoder mode, RDM function.
- Easy operation with OLED display and 3 buttons.
- 1/2/3/4/5 channel decoding mode selectable.
- PWM frequency 250/500/2000/8000/16000Hz selectable.
- 16bit (65536 levels) /8bit (256 levels) grey level selectable.
- Output dimming curve gamma value 0.1-9.9 selectable.
- Stand-alone RGB mode and 5 channel dimmer mode selectable, work as DMX master(8 bit) to control other decoders.
- Built-in 25 RGB programs, speed and brightness adjustable.
- Support 3 kinds of DMX ports: Green terminal(amplify output), XLR5 and RJ45 port.
- Comply with the DMX512 standard protocols.
- Over-heat / Over-load / Short circuit protection, recover automatically.
- With fast self-testing function.



CE RoHS emc RED

### Technical Parameters

Input and Output		Safety and EMC		Environment	
Input voltage	12-24VDC	EMC standard(EMC)	ETSI EN 301 489-1 V2.2.3	Operation temperature	Ta: -30°C ~ +55°C
Input current	30.5A		ETSI EN 301 489-17 V3.2.4	Case temperature (Max.)	Tc: +75°C
Output voltage	5 x (12-24)VDC	Safety standard	EN 61348-1:2015+A1:2021	IP rating	IP20
Output current	5CH, 6A/CH		EN 61348-2-13:2014+A1:2017	<b>Package</b>	
Output power	5 x (72-144)W	Radio Equipment(RED)	ETSI EN 300 328 V2.2.2	Size	L170 x W87 x H45mm
Output type	Constant voltage	Certification	CE, EMC, RED	Gross weight	0.49kg
		Warranty	5 years		

### Mechanical Structures and Installations

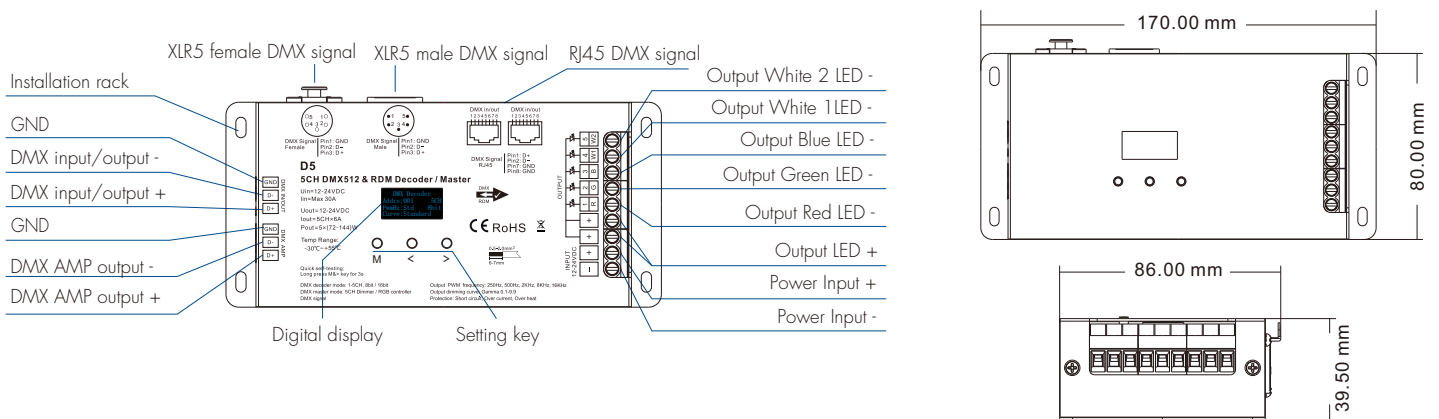

### Wiring Diagram

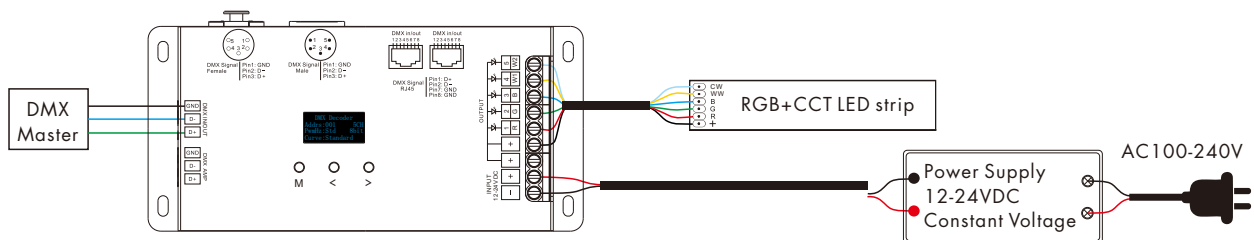

**Note:**

1. Connecting with green terminal(DMX AMP) or an extra amplifier will be needed when more than 32 decoders are connected, or use overlong signal line, signal amplification should not be more than 5 times continuously.
2. If the recoil effect occurs because of longer signal line or bad line quality, please try to connect 0.25W 90-120Ω terminal resistor at the end of each DMX signal line.

## OLED screen interface

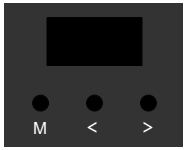

Short press M key, switch between DMX decoder mode, Dimmer mode and RGB controller mode.

Long press M key or short press < or > key, enter parameter setting state.

When in parameter setting state, short press M key to switch between multiple parameter item, press < or > key for parameter adjustment.

long press M key or wait 30s to quit parameter setting state.

Long press M & > key for 2s, enter fast self-testing.

Long press < & > key for 2s, restore factory default parameter.

### DMX decoder mode

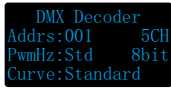

DMX decode start address: 001~512

DMX decode mode: 1CH (DIM) 2CH (CCT) 3CH (RGB) 4CH (RGBW) 5CH (RGB+CCT)

Output PWM frequency:

Std (2KHz)

High (8KHz)

Mid (500Hz)

Low (250Hz)

Supr (16KHz)

Higher PWM frequency, will cause lower output current, higher power noise, but more suitable for camera(No flickers for video).

Grey level:

8bit

16bit (choose it if the DMX master support 16 bit)

Output dimming curve(Only valid for 8bit Grey level):

Standard (Gamma 1.6)

Linear

Gamma0.1-9.9

It is recommended to use standard,

0.1-9.9 is for special requirements, long press < or > key to change 0.1-9.9.

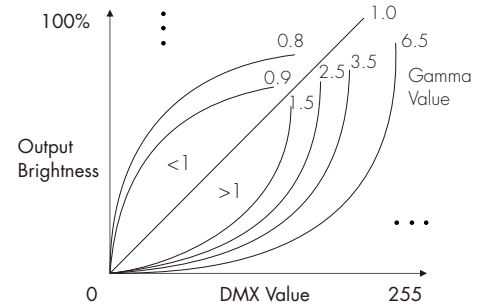

### DMX master mode as 5 channel dimmer

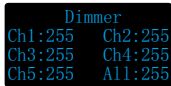

Each or all channel brightness setting: 0-255 (0-100%)

### DMX master mode as RGB+CCT controller



Dynamic RGB mode: 25 kinds

Mode speed: 1-10 level, level 10 fastest speed

Mode brightness: 10%-100%

Ch4 brightness: 0-255 (0-100%)

Ch5 brightness: 0-255 (0-100%)

### Dynamic RGB mode list:

No.	Name	No.	Name	No.	Name
01	Static Red+strobe	09	R/G/B gradual	17	Green/White gradual
02	Static Green+strobe	10	Color gradual	18	Blue/White gradual
03	Static Blue+strobe	11	R/G/B fade	19	Red/Yellow gradual
04	Static White+strobe	12	Red fade	20	Red/Purple gradual
05	R/G/B jump	13	Green fade	21	Green/Yellow gradual
06	7 Color jump	14	Blue fade	22	Green/Cyan gradual
07	R/G/B strobe	15	White fade	23	Blue/Purple gradual
08	7 Color strobe	16	Red/White gradual	24	Blue/Cyan gradual
				25	All loop play

## Address setting table

### 8bit:

Decode Mode	1CH DIM	2CH CCT	3CH RGB	4CH RGBW	5CH RGB+CCT
Address Quantity	1	2	3	4	5
Channel	1	001	001	001	001
	2	001	002	002	002
	3	001	001	003	003
	4	001	002	003	004
	5	001	002	003	004

### 16bit:

Decode Mode	1CH DIM	2CH CCT	3CH RGB	4CH RGBW	5CH RGB+CCT
Address Quantity	2	4	6	8	10
Channel	1	001 002	001 002	001 002	001 002
	2	001 002	003 004	003 004	003 004
	3	001 002	001 002	005 006	005 006
	4	001 002	003 004	005 006	007 008
	5	001 002	003 004	005 006	007 008

Note: even channel for micro dimming.

## Malfunctions analysis & troubleshooting

Malfunctions	Causes	Troubleshooting
No light	1. No power. 2. Wrong connection or insecure.	1. Check the power. 2. Check the connection.
Wrong color	1. Wrong connection of R/G/B/W wires. 2. DMX decode address error.	1. Reconnect R/G/B/W wires. 2. Set correct decode address.
Uneven intensity between front and rear, with voltage drop	1. Output cable is too long. 2. Wire diameter is too small. 3. Overload beyond power supply capability. 4. Overload beyond controller capability.	1. Reduce cable or loop supply. 2. Change wider wire. 3. Replace higher power supply. 4. Add power repeater.